

**PEI CHUN PUBLIC SCHOOL**  
**SCIENCE PRELIMINARY EXAMINATION, 2015**

**SCIENCE**  
**SECTION A**

**Time: 1 h 45 min**

Name : \_\_\_\_\_

Class : Primary 6 \_\_\_\_\_

Date : 18 August 2015

Parent's Signature: \_\_\_\_\_

**INSTRUCTIONS TO CANDIDATES**

**DO NOT OPEN THIS BOOKLET UNTIL YOU ARE TOLD TO DO SO.**

**FOLLOW ALL INSTRUCTIONS CAREFULLY.**

**ANSWER ALL QUESTIONS.**

**WRITE YOUR ANSWERS IN THIS BOOKLET.**

**Section A (30 × 2 marks)**

For questions 1 to 30, choose the most suitable answer and shade its number (1, 2, 3 or 4) on the Optical Answer Sheet (OAS) provided.

1. The diagram below shows how different groups of birds are classified according to certain characteristics, A, B, P, Q, S and T.

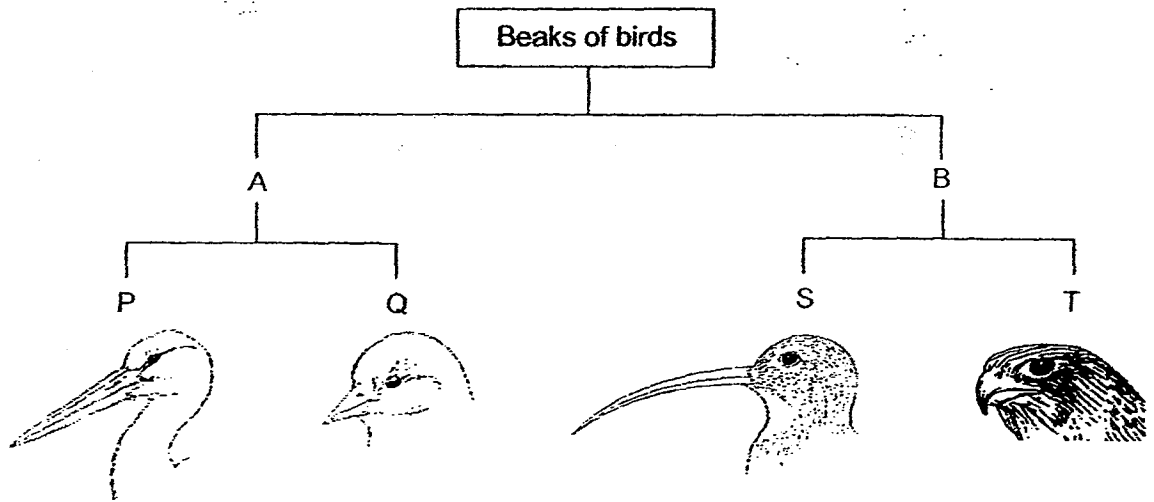

Which of the following correctly shows the characteristics A and T?

	A	T
(1)	straight beak	curved beak
(2)	straight beak	beak shorter than head
(3)	beak longer than head	curved beak
(4)	beak longer than head	beak shorter than head

2. Aini observed four materials P, Q, R and S and recorded her observations in the table below.

Material	Waterproof	Allow most light to pass through	Flexible
P	✓	✓	
Q	✓	✓	✓
R	✓		✓
S			✓

The diagram below shows a car.

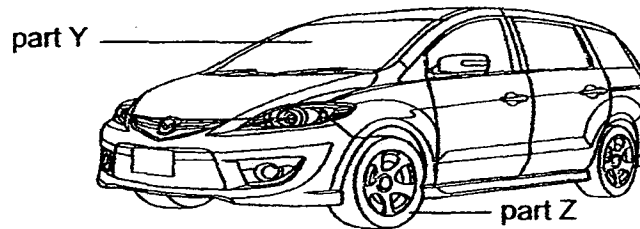

Based on the information above, which of the following materials are most suitable for making parts Y and Z?

	Part Y	Part Z
(1)	R	P
(2)	P	S
(3)	Q	S
(4)	P	R

3. Study the diagram below.

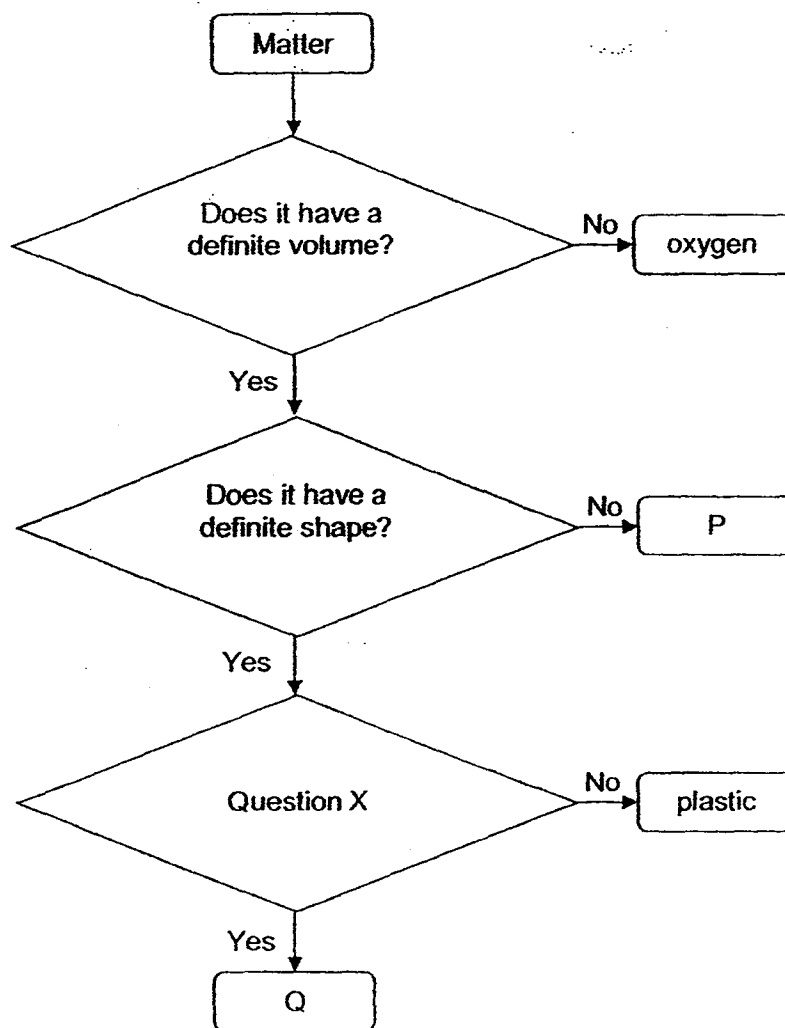

Which of the following correctly states what P, question X and Q are?

	P	Question X	Q
(1)	air	Is it a good conductor of heat?	copper
(2)	water	Is it a good conductor of heat?	steel
(3)	carbon dioxide	Is it a magnetic material?	iron
(4)	oil	Is it a magnetic material?	copper

4. Nurul has a plant as shown below.

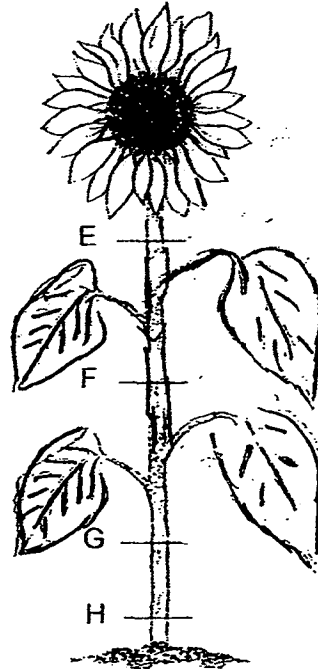

She removed an outer ring of the stem from the plant. As a result, the food-carrying tubes were removed while the water-carrying tubes remained in the stem. The diagram below shows the appearance of the stem near the removed ring after one week.



At which part of the stem did Nurul most likely remove the outer ring?

- (1) E
- (2) F
- (3) G
- (4) H

5. The figure below shows how gases are transported in the circulatory system of a fish.

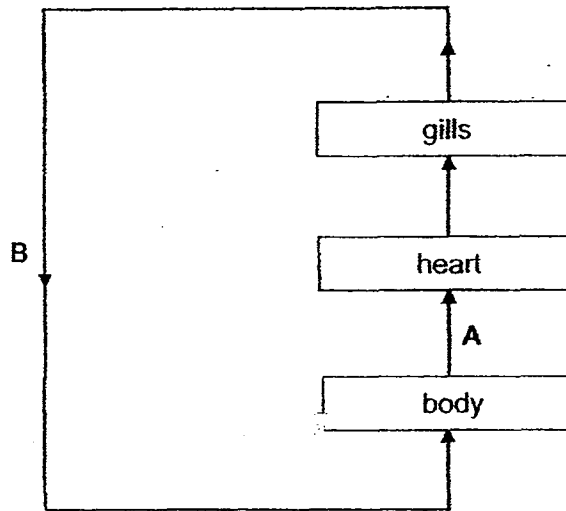

When compared with the blood in B, the blood in A has \_\_\_\_\_.

- (1) less oxygen and less carbon dioxide
  - (2) less oxygen and more carbon dioxide
  - (3) more oxygen and less carbon dioxide
  - (4) more oxygen and more carbon dioxide
6. A class carried out an experiment on photosynthesis to find out if the **brightness of the light will affect the amount of gas produced**. The pupils set up the apparatus as shown below. When they put the set-up under the light, they observed bubbles in the water.

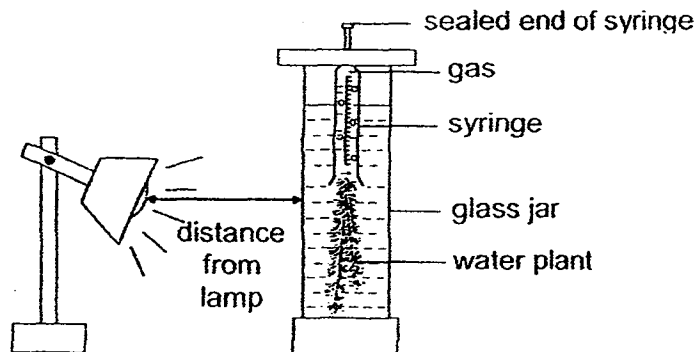

In order to ensure a fair test, the pupils should only change the \_\_\_\_\_.

- (1) amount of plant used
- (2) type of water plant used
- (3) amount of water in the glass jar
- (4) distance between the lamp and the glass jar

7. The diagram shows a hydroelectric power station.

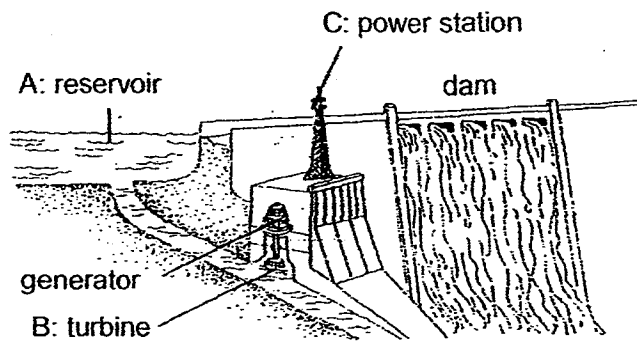

Which of the following best describes the energy changes that take place from part A to part B to part C as shown in the diagram?

- (1) potential energy  $\rightarrow$  kinetic energy  $\rightarrow$  electrical energy
- (2) chemical energy  $\rightarrow$  kinetic energy  $\rightarrow$  electrical energy
- (3) kinetic energy  $\rightarrow$  electrical energy  $\rightarrow$  chemical energy
- (4) potential energy  $\rightarrow$  electrical energy  $\rightarrow$  kinetic energy

8. Rubbish in a city was collected and disposed by burning, burying or dumping. The table shows that:

- i) the amount of rubbish collected in 1998 was more than that in 1995.
- ii) the amount of rubbish disposed of in 1998 was less than that in 1995.

Year	Rubbish (in million kg)	
	Collected	Disposed of
1995	4000	3900
1998	4100	3100

Which is the possible reason to explain why less rubbish was disposed of in 1998?

- (1) The population in 1998 was smaller.
- (2) More incinerators were built in 1998.
- (3) More dumping grounds were available in 1998.
- (4) More rubbish-recycling plants were built in 1998.

9. The diagram shows two points in a river, where water samples were taken.

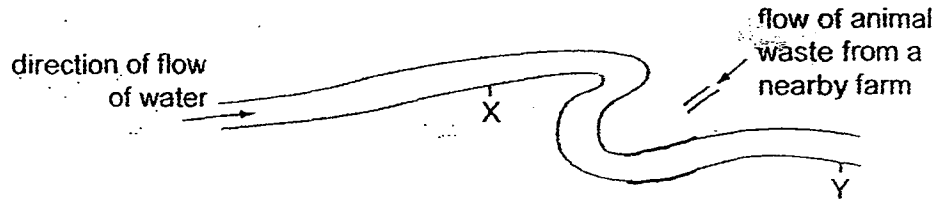

The graph below shows the amount of dissolved oxygen in the river.

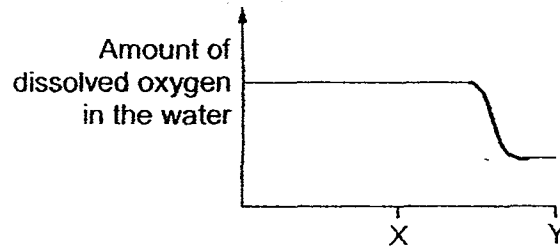

Which of the following best explains the change in the amount of dissolved oxygen in the river between point X and Y?

Point Y has \_\_\_\_\_ than point X.

- (1) fewer fishes
- (2) more bacteria
- (3) fewer floating water plants
- (4) more dissolved carbon dioxide

10. Gopal studied a community living in a leaf litter. He found the following organisms:

earthworms	woodlice	toadstools	moulds
------------	----------	------------	--------

Which of the following classification is correct?

	Decomposers	Organisms that help decomposers
(1)	toadstools, moulds	earthworms, woodlice
(2)	woodlice, toadstools	earthworms, moulds
(3)	earthworms, woodlice, toadstools	moulds
(4)	moulds, earthworms, toadstools	woodlice



11. The diagram below shows the human digestive system.

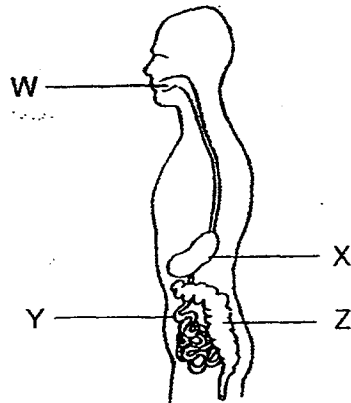

Where does digestion take place?

- (1) X and Y only
- (2) X and Z only
- (3) W, X and Y only
- (4) W, Y and Z only

12. Weiming wanted to find out how the amount of electric current flowing in a circuit is affected by the length of wire used in the circuit.

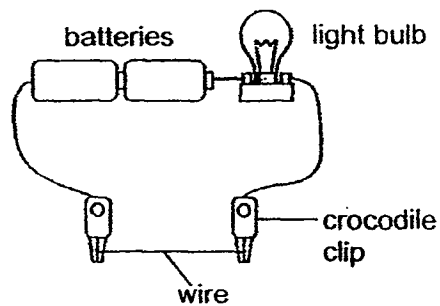

Which of the following should be kept constant for a fair test?

- A : Length of wire
  - B : Thickness of wire
  - C : Number of batteries
  - D : Brightness of light bulb
- (1) A only
  - (2) B and C only
  - (3) A, C and D only
  - (4) B, C and D only

13. The diagram below shows two shapes, R and S, made of tracing paper.

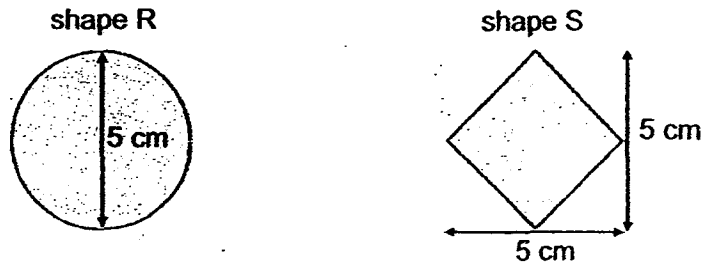

The two shapes are placed between a torch and a screen as shown below.

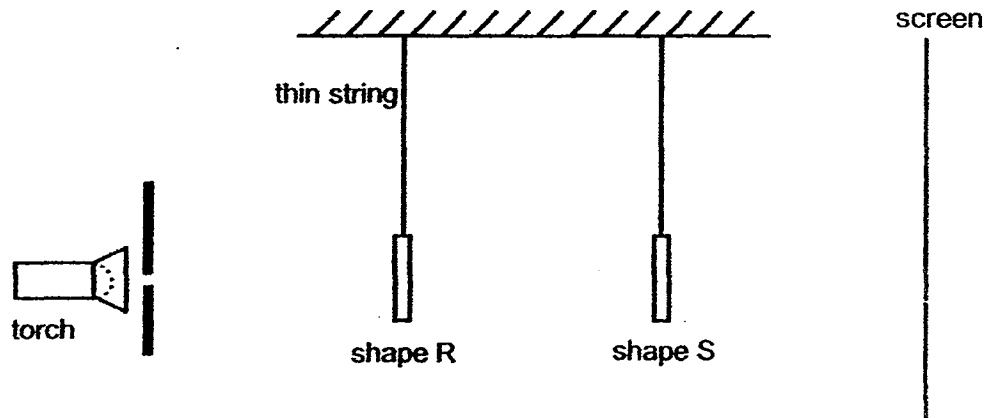

Which of the following correctly shows the shadow formed on the screen?

(1)

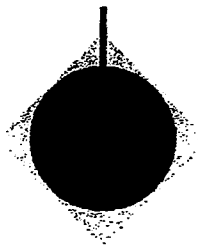

(2)

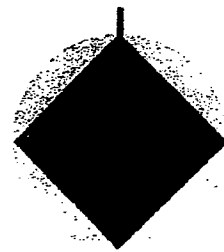

(3)

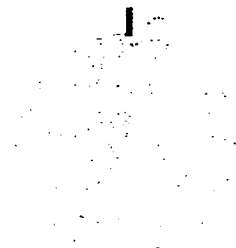

(4)

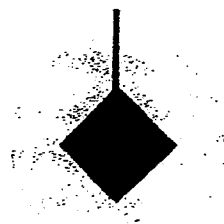

14. Bulbs B1, B2 and B3, and switches S1, S2, S3 and S4 are connected in a circuit as shown below. All the bulbs are working properly.

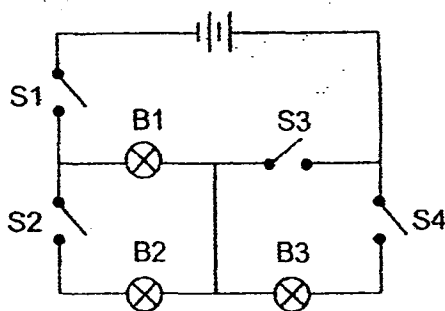

Which of the following observations is correct?

	S1	S2	S3	S4	Which of the bulbs is/are lit?
(1)	closed	closed	open	closed	B2 and B3 only
(2)	closed	closed	closed	open	B1 and B2 only
(3)	closed	open	open	closed	B1 only
(4)	open	closed	closed	closed	B1, B2 and B3

15. Si Qing had four rods, A, B, C and D, of unknown materials. She connected the rods in the two circuits shown below. Bulbs S and T were working properly.

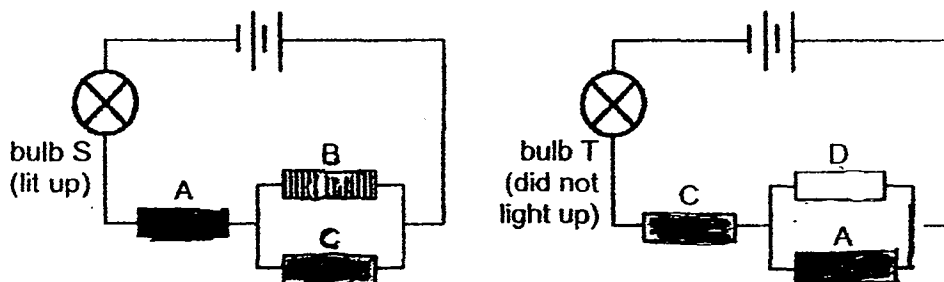

She observed that only bulb S lit up.

Which of the following correctly describes rods A, B, C and D?

	Does it conduct electricity?			
	A	B	C	D
(1)	yes	yes	yes	no
(2)	yes	not sure	no	not sure
(3)	no	yes	yes	no
(4)	yes	yes	no	not sure

16. The diagram below shows a tree frog gliding from one tree to another.



Which of the following characteristics help the frog to stay longer in the air?

Characteristics	
streamlined body	webbed feet
(1) yes	yes
(2) yes	no
(3) no	yes
(4) no	no

17. The food web shows the relationship between organisms A, B, C, D and E.

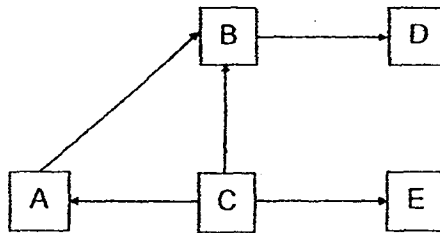

Which of the following classification is correct?

	prey	prey and predator	predator
(1)	A	B	D
(2)	A	B	D and E
(3)	A and E	B	D
(4)	C	A and B	D and E

18. Suzie carried out an experiment to study the decomposition of dead leaves. She placed some dead leaves and dry soil in a bottle as shown below.

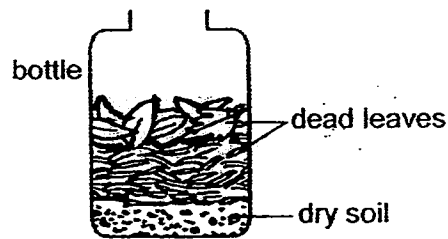

Which of the following could Suzie possibly do to make the dead leaves decompose faster?





- A : Use damp soil instead of dry soil.  
 B : Place the container in a cold and dark place.  
 C : Cover the opening of the container with a lid.

- (1) A only  
 (2) A and C only  
 (3) B and C only  
 (4) A, B and C

19. The table below shows how some insects can be grouped.

	Has wings	Does not have wings
Has 3 stages in its life cycle	E	G
Has 4 stages in its life cycle	F	H

The diagrams below show insects X and Y.

Insect X		Insect Y	
			
young	adult	young	adult

Which group, E, F, G or H, do insects X and Y belong to?

	Insect X	Insect Y
(1)	E	G
(2)	E	H
(3)	F	G
(4)	F	H

20. Four similar rods, E, F, G and H, of different materials are heated as shown below. The rods are of the same thickness and length. Each rod has the same amount of wax attached at one end.

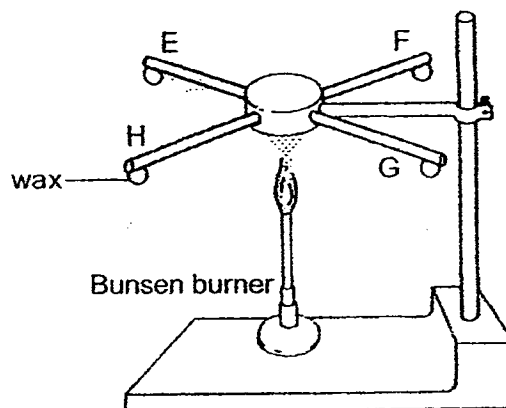

The table below shows the time taken for each piece of wax to melt and drop.

Rods	Time taken for the piece of wax to melt and drop(s)
E	5
F	35
G	15
H	8

Based on the results above, which of the following statements is true?

- (1) Rod F is the best insulator of heat.
  - (2) Rod H is the best conductor of heat.
  - (3) Rod E conducts heat slower Rod G.
  - (4) All the rods are metals as they are able to conduct heat.
21. The table below shows the melting and boiling points of two substances, X and Y.

Substance	Melting Point ( °C)	Boiling Point (°C)
X	35	250
Y	100	150

Which of the following shows the correct states of X and Y at 95 °C?

	X	Y
(1)	solid	liquid
(2)	solid	gas
(3)	liquid	liquid
(4)	liquid	solid

22. Rahim placed two chairs in his room as shown below.

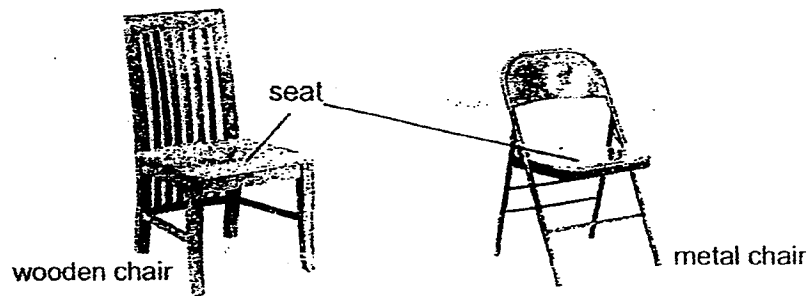

He placed his left hand on the seat of the wooden chair and his right hand on the metal chair.

Which of the following correctly described his observation and reason?

	Observation	Reason
(1)	The wooden chair was warmer.	Wood is a better conductor of heat than metal.
(2)	The metal chair was cooler.	The metal chair gained heat from the hand faster than the wooden chair.
(3)	The metal chair was cooler.	The wooden chair gained heat from the hand faster than the metal chair.
(4)	Both chairs feel the same.	Both chairs were at room temperature.

23. The table below records the number of organisms that could be found near and in a pond community in half an hour.

Organisms	Number of organisms
cattail	3
dragonflies	8
dragonfly nymphs	7
frogs	12
hydrilla	11
mosquitoes	20
mosquito larvae	15
tadpoles	23

How many populations could be found in the above community?

- (1) 5
- (2) 6
- (3) 8
- (4) 99

24. The diagram below shows the family tree of Henry.

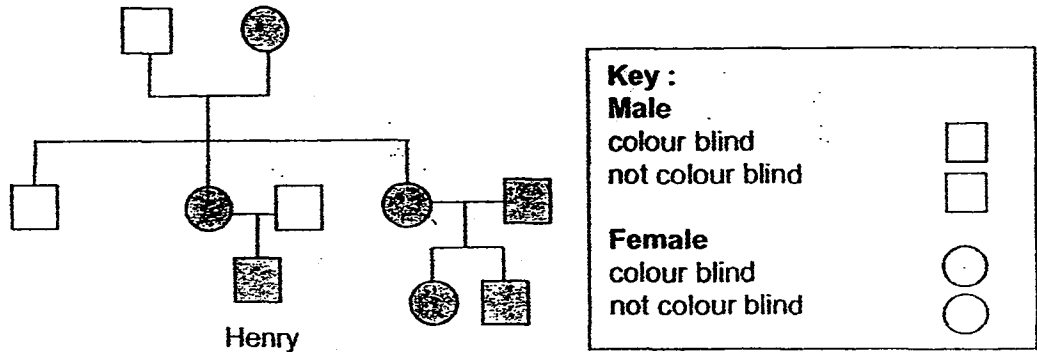

- A : All the males in the family are colour blind.
- B : Henry has two aunts who are colour blind.
- C : Henry inherited colour blindness from his mother.
- D : Henry's grandfather has three grandchildren who are colour blind.

Based on the family tree, which of the above statements is/are correct?

- (1) A only
- (2) B and C only
- (3) C and D only
- (4) A, C and D only

25. The diagrams below show the human reproductive systems.

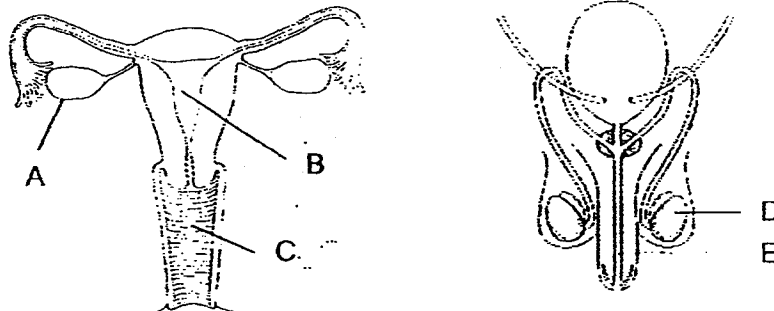

Which of the following correctly shows where the reproductive cells are produced?

	Female reproductive cell	Male reproductive cell
(1)	A	E
(2)	A	D
(3)	B	D
(4)	C	E



26. Study the set-ups A and B below. Identical flasks and glass tubes were used.

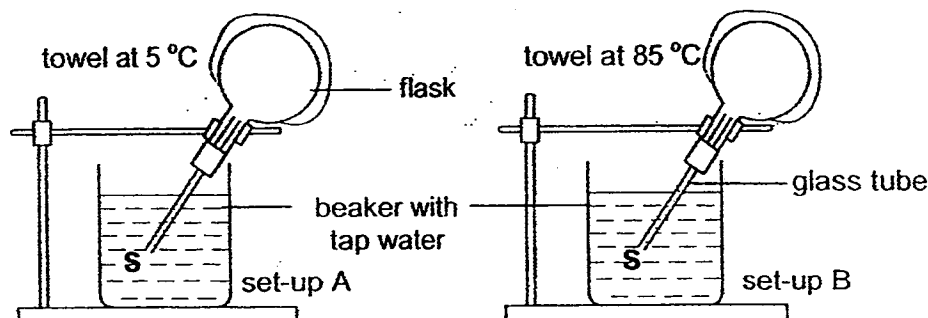

Which of the following could be observed a few minutes after the towels were placed on the flasks in set-ups A and B?

	Observation for A	Observation for B
(1)	water rises up the tube	water rises up the tube
(2)	water rises up the tube	bubbles escape from the tube at S
(3)	bubbles escape from the tube at S	water rises up the tube
(4)	bubbles escape from the tube at S	bubbles escape from the tube at S

27. Ben, May and Ron conducted an experiment as shown below. They poured the same amount of water of different temperatures into two identical beakers and left the beakers on the classroom table.

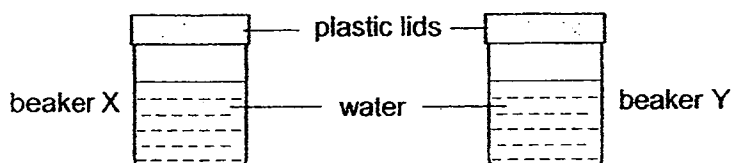

After a few minutes, they observed that water droplets were formed on the two beakers as shown below.

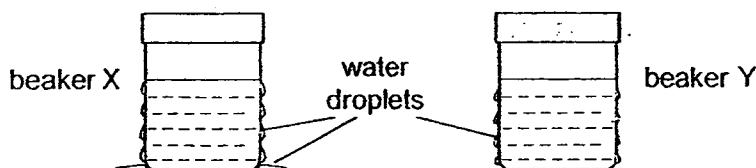

Three pupils gave their explanations of their observation.

Ben : The temperature of the water in beaker X was lower than room temperature.

May : Condensation took place faster on the outer surface of beaker X than on beaker Y.

Ron : The temperature of the water in beaker X was higher than that in beaker Y.

Which pupil gave the correct explanation?

- (1) Ben only
- (2) Ron only
- (3) Ben and May only
- (4) May and Ron only

28. Richard secured two magnets, A and B, on top of two cars, Y and Z. The cars were placed facing each other at a distance, as shown below.

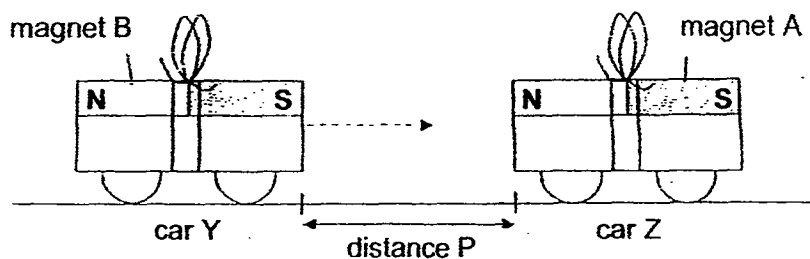

Richard pushed car Y slowly towards car Z. He recorded distance P where car Y and car Z started to move towards each other on their own.

He repeated his experiment with magnet C and magnet D on car Y. The table below shows the results of his experiment.

Magnet	Distance P (cm)
B	6
C	4
D	8

Based on his results, which of the following statements is/are definitely correct?

- A : Magnet C is weaker than magnet B.
  - B : Magnet B is stronger than magnet D.
  - C : Magnet D is stronger than magnets B and C.
  - D : Magnet D is the strongest of the four magnets.
- (1) B only  
(2) A and C only  
(3) B and D only  
(4) A, C and D only

29. Study the diagram below.

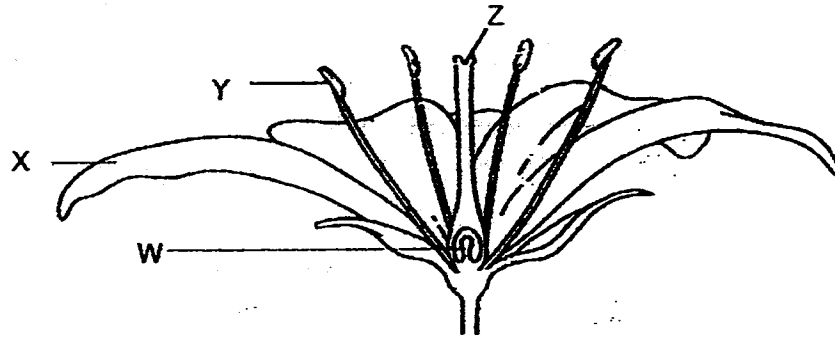

A gardener carried out an experiment on four fully-bloomed flowers on the same plant. He removed different parts of the flowers and left the plant in the garden. The table below shows the parts which he removed from the flowers.

Parts of flowers	Flower A	Flower B	Flower C	Flower D
W				removed
X		removed	removed	
Y	removed	removed		
Z	removed		removed	removed

Based on the table above, which of the flowers has the highest chance of forming fruits?

- (1) A
- (2) B
- (3) C
- (4) D

30. Study the food chain shown below carefully.

R → W → X → Y → Z

If Organism Y is removed from the above food chain, which one of the following graphs correctly shows the changes in the other populations?

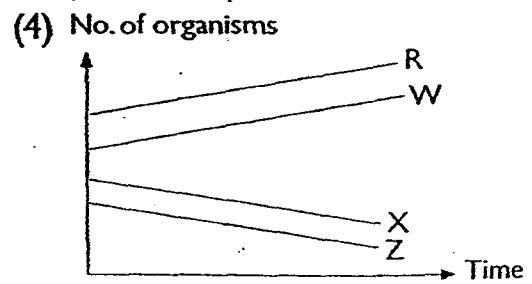
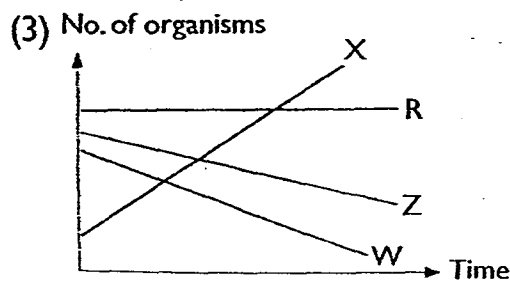
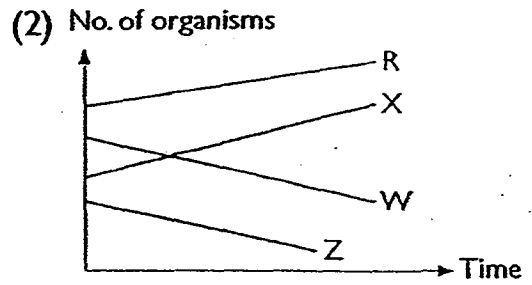
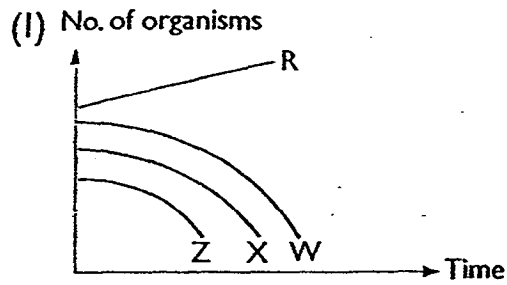

**PEI CHUN PUBLIC SCHOOL**  
**SCIENCE PRELIMINARY EXAMINATION, 2015**

**SCIENCE**  
**SECTION B**

Time: 1 h 45 min

Name : \_\_\_\_\_

Class : Primary 6 \_\_\_\_\_

Date : 18 August 2015

Parent's Signature: \_\_\_\_\_

<b>SECTION A</b>	<b>60</b>
<b>SECTION B</b>	<b>40</b>
<b>TOTAL</b>	<b>100</b>

**INSTRUCTIONS TO CANDIDATES**

DO NOT OPEN THIS BOOKLET UNTIL YOU ARE TOLD TO DO SO.

FOLLOW ALL INSTRUCTIONS CAREFULLY.

ANSWER ALL QUESTIONS.

WRITE YOUR ANSWERS IN THIS BOOKLET.

**Section B (40 marks)**

For questions 31 to 44, write your answers in the spaces provided.

31. Gerald wanted to find out if water plants affect the amount of carbon dioxide in the water at different times of the day. He used the set-ups shown below.

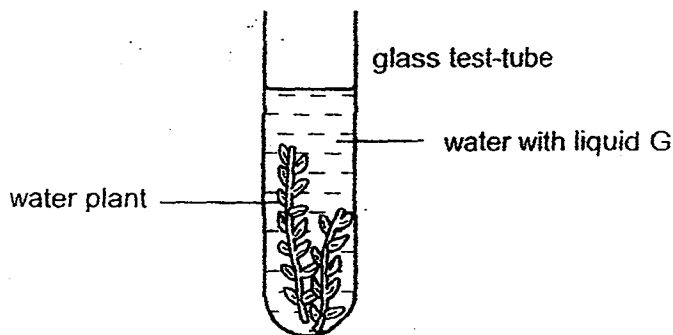

He placed the set-up near a window and added a few drops of liquid G to the water. Liquid G changes colour as shown below.

<b>Amount of carbon dioxide in water</b>	less than normal	normal	higher than normal
<b>Colour of water with liquid G</b>	purple	red	yellow

- a) What colour would the water with liquid G be at 3 p.m. and 3 a.m.? Complete the table below.

[ 2 ]

	<b>Start (6 a.m.)</b>	<b>3 p.m.</b>	<b>3 a.m.</b>
<b>Colour of water with liquid G</b>	red		

- b) Gerald conducted another experiment as shown below. He added the same amount of water plants and water in two identical glass test-tubes. He wrapped test-tube X in a layer of tracing paper.

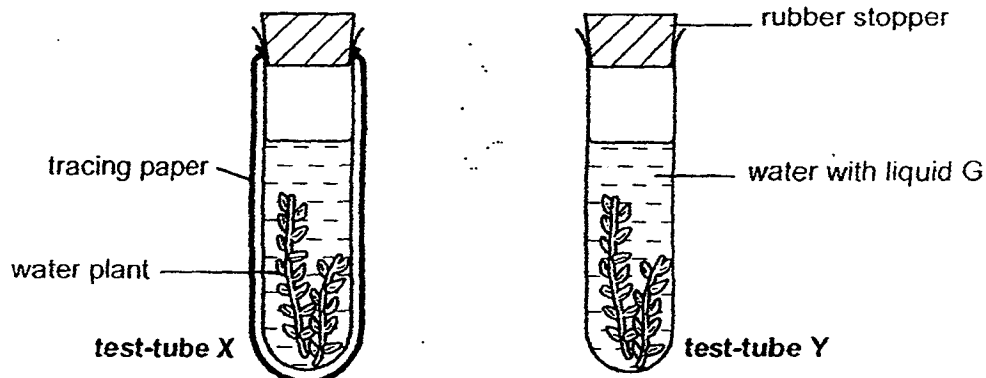

He added three drops of liquid G to the water in each test-tube before sealing them up with rubber stoppers. The two test-tubes were placed the same distance away from a table-lamp that was switched on.

He observed that the time taken for the colour of the water in test-tube Y to change was shorter than that of test-tube X. Explain his observation.

[ 1 ]

---



---

32. Zainal picked up a fruit with a wing-like structure from the ground as shown below.

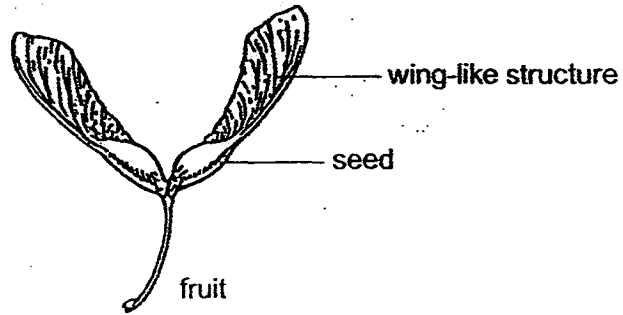

He decided to carry out an investigation on the fruit. He found three similar fruits, A, B and C, and cut off part of the wing-like structures on fruits B and C.

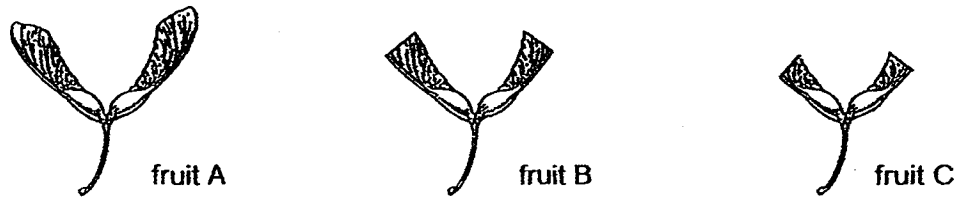

He then dropped each fruit from the same height and recorded the time taken for the fruit to reach the ground. He recorded his results in the table shown below.

Fruit	Surface area of the fruit (cm)	Time taken for the fruit to reach the ground (s)
A	7.9	4.7
B	5.4	3.1
C	3.8	2.6

- a) What is the aim of Zainal's experiment? [ 1 ]

---

---

- b) What should Zainal do to ensure that the results of his experiment are more reliable? [ 1 ]

---

---

33. Joshua wanted to investigate the effect of surface area of water exposed to the air on the rate of cooling of hot water. He poured an equal amount of hot water into two plastic containers, A and B, as shown below. Both containers were wrapped with the same heat insulator.

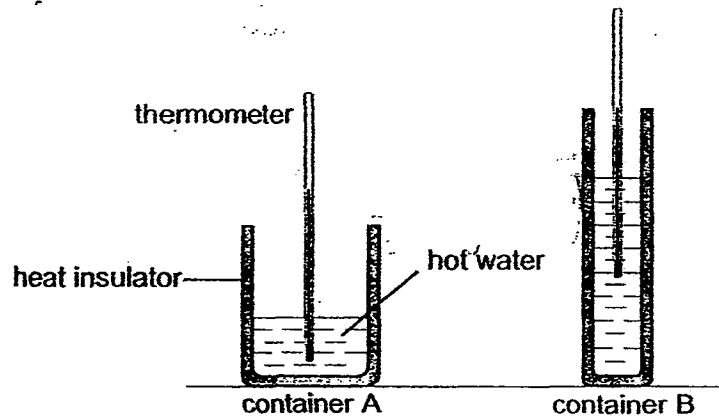

He placed the two containers side by side on a table and recorded the temperature of the water in each of the containers.

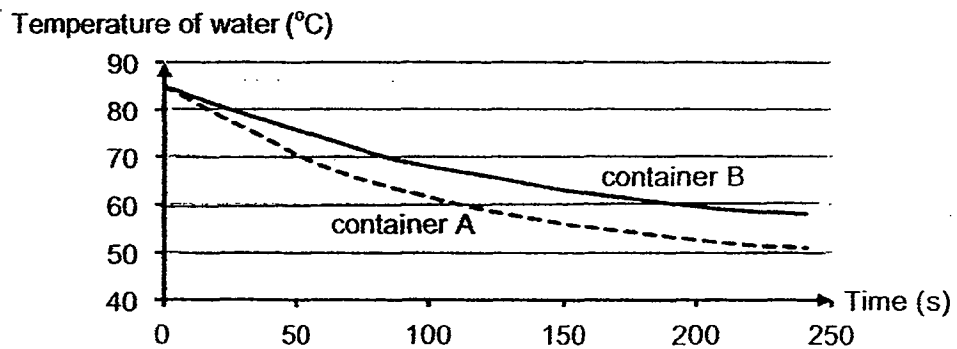

His results are shown below.



- a) Explain why the temperature of the hot water decreased with time. [ 1 ]
- 
- 
- b) Based on Joshua's results, state how the surface area of water exposed to the air affects the rate of cooling of hot water. [ 1 ]
- 
-



- c) The diagrams below show two animals, J and K. The two animals are of about the same mass and body size.

 <p><b>animal J</b></p> <ul style="list-style-type: none"> <li>• big ears</li> <li>• short forelegs and long hindlegs</li> <li>• long tail</li> </ul>	 <p><b>animal K</b></p> <ul style="list-style-type: none"> <li>• small ears</li> <li>• short legs</li> <li>• short tail</li> </ul>
--	--

Which animal, J or K, is able to survive better in a cold environment?  
Based on Joshua's experimental findings, explain your answer.

[ 2 ]

---



---



---



---

34. The diagram below shows a single-celled organism which lives in pond water.

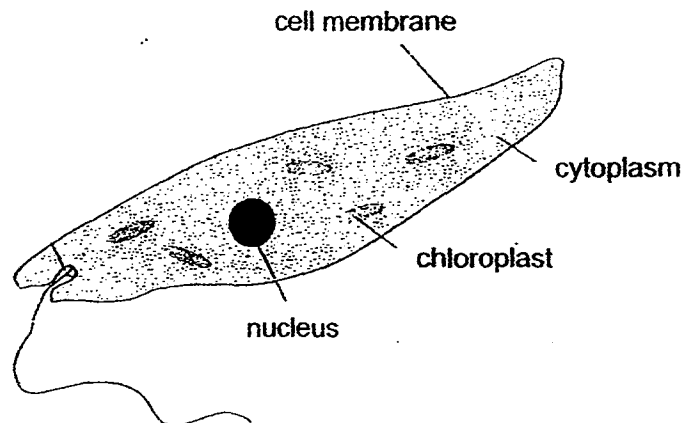

Use the information in the diagram to answer the following questions.

- a) Give a reason why this organism is more likely to be an animal cell than a plant cell.

[ 1 ]

---



---

- b) State one part inside this organism that is not found in a typical animal cell.

[ 1 ]

---

35. Study the graphs below.

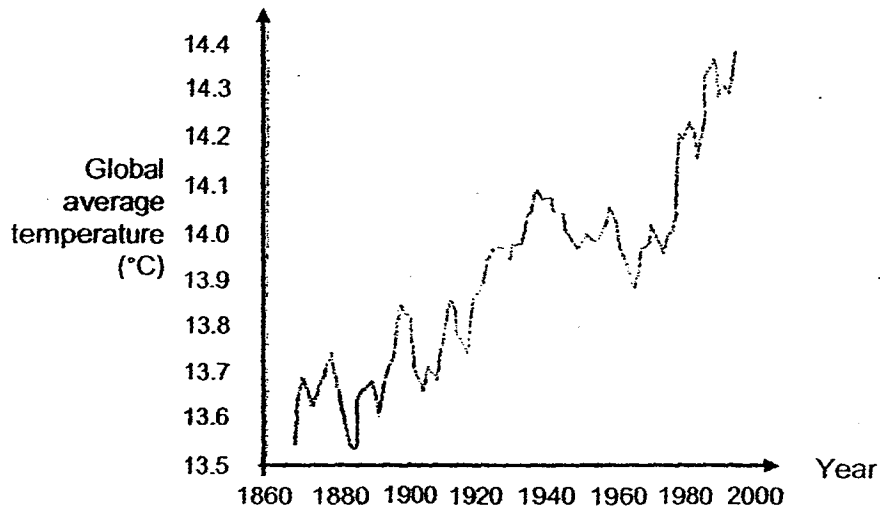
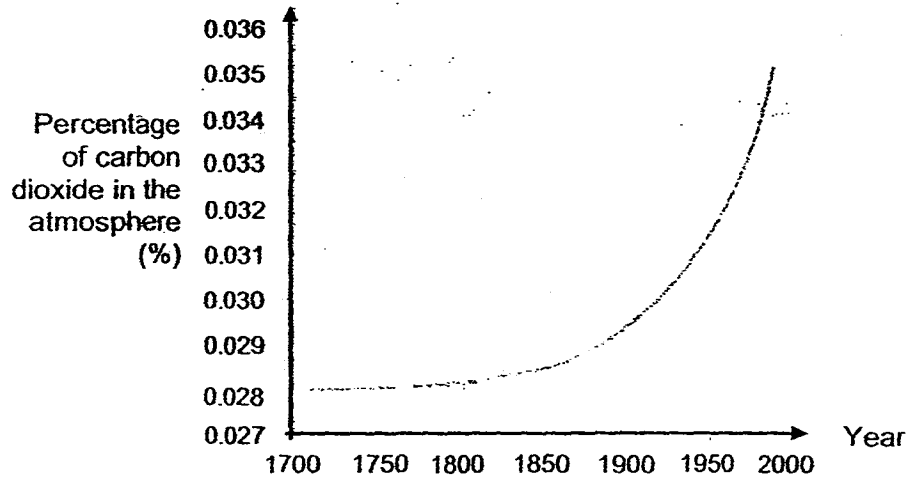

a) Describe the relationship between the global temperature and the amount of carbon dioxide in the air. [ 1 ]

---

---

b) Explain how removing a large number of trees from forests would lead to global warming. [ 2 ]

---

---

---

---

36. The fruit of plant B has a hard pod and has many seeds in the pod. Its seeds are a source of food for animal A.

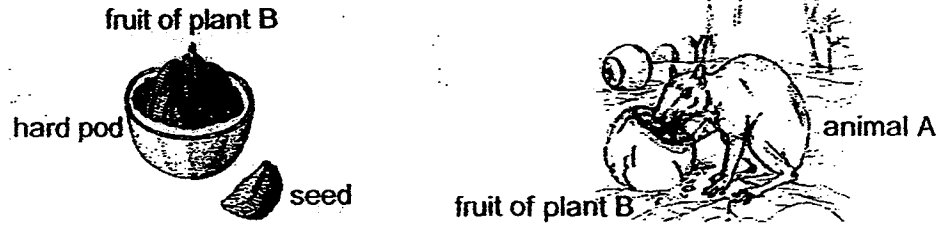

After animal A has eaten some of the seeds, it will store the rest of the seeds by burying them separately in a different place. It usually buries more seeds that it would eat later on.

- a) Explain how having many seeds in one fruit helps plant B in its survival. [ 1 ]

---



---

- b) A scientist counted the number of seeds buried by animal A at various distances from the parent plant. The results are shown below.

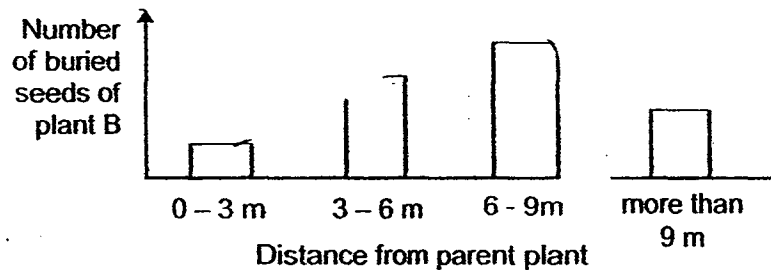

- Based on the information given above, explain how animal A benefits plant B. [ 1 ]

---



---

- c) State one benefit for animal A to bury each seed in a different place. [1]

---



---

37. The diagram below shows a food chain in a forest.



The graph below shows the changes in the populations of animals A and B over a three-year period.

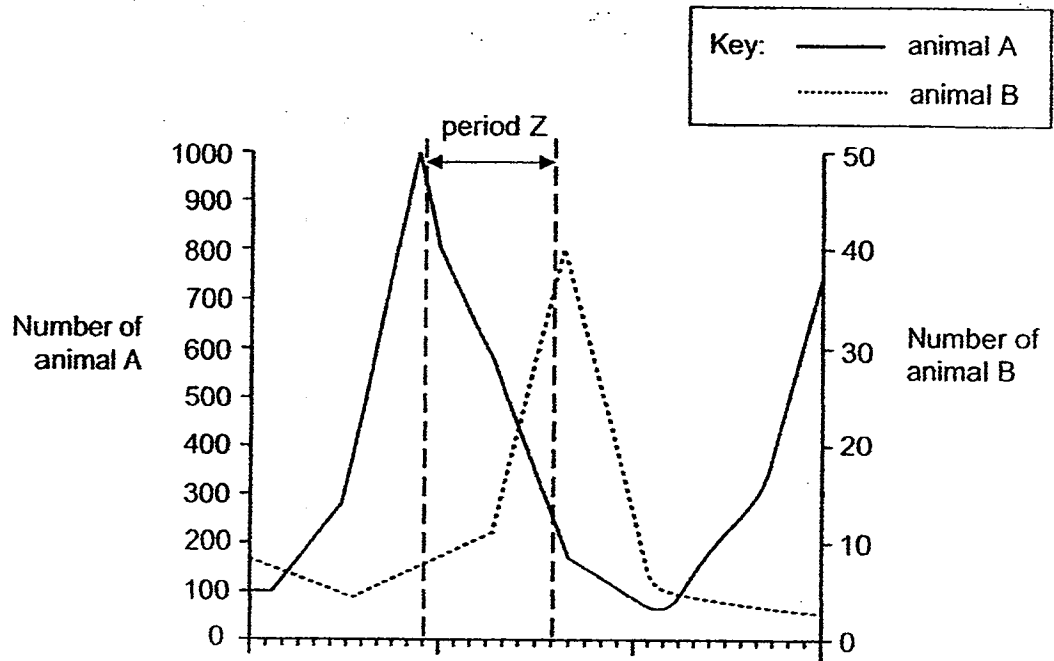

Using the information given in the food chain and the graph, suggest **two** possible reasons why the population of animal A decreased during period Z. [ 2 ]

Reason 1:

---

---

Reason 2:

---

---

38. Alijah set up two similar terrariums and placed them in the cupboard. Terrarium A is airtight but terrarium B has holes.

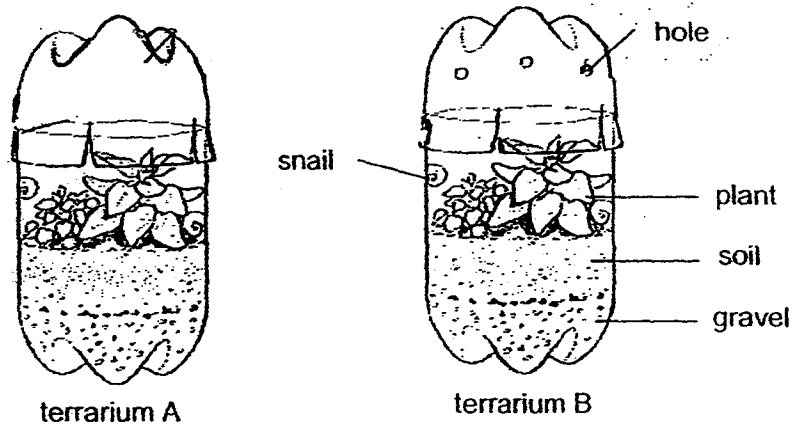

- a) Based on the set-ups above, which terrarium, A or B, would have a higher amount of carbon dioxide after five hours? Give a reason for your answer. [ 1 ]

---

---

---

- b) She realised that there were water droplets on the inner side of Terrarium A. Explain the observation that Alijah had from the set-up. [ 2 ]

---

---

---

---

39. Yelin lowered an empty glass into a container of water as shown below. She observed that the paper that was glued inside the glass remained dry.

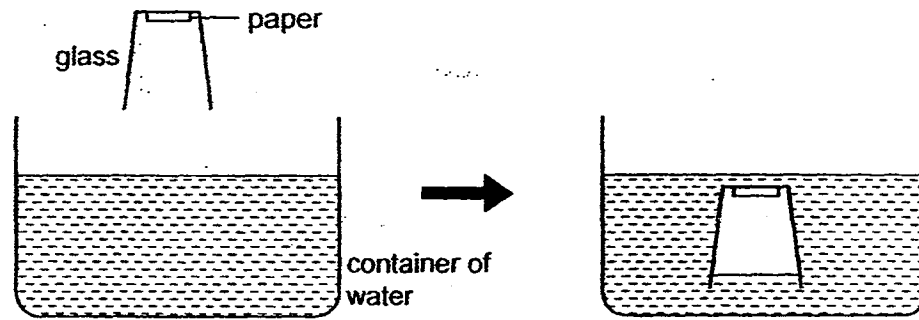

- a) Give a reason for her observation.

[ 1 ]

---

---

- b) A large strong glass container is attached to a ship by a strong rope. It can be lowered into the sea until it is completely under water as shown below. A person sitting inside the glass container can study sea animals.

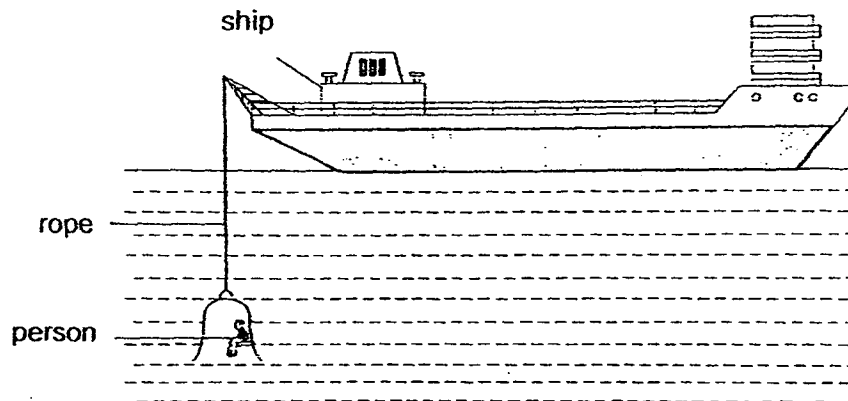

Give a reason why a person cannot remain in the glass container for a long period of time.

[ 1 ]

---

---

40. The diagram below shows a piling machine. The hammer falls and drives the pile into the ground.

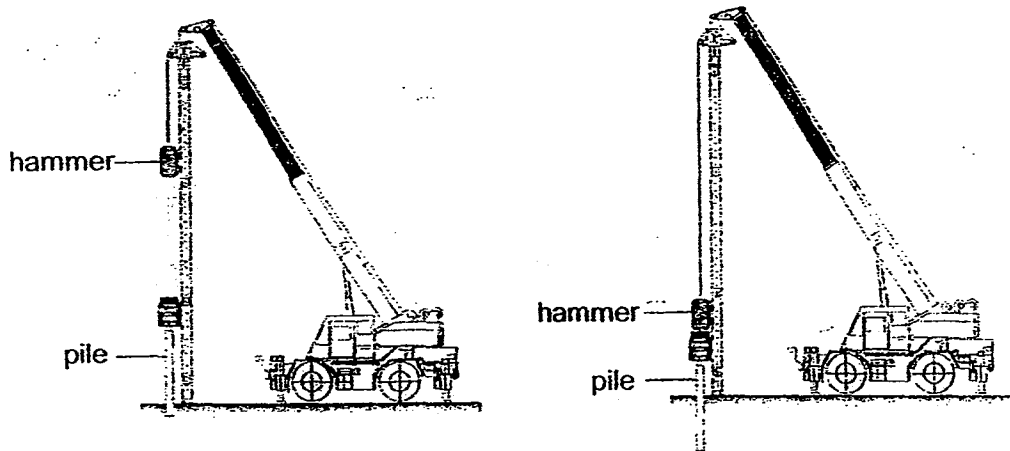

- a) In the boxes below, write the energy changes when the hammer falls and drives the pile into the ground. [ 2 ]

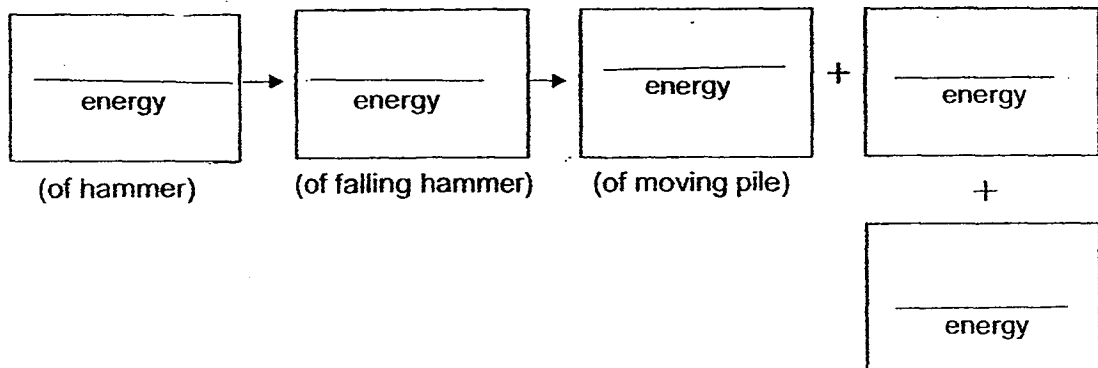

- b) Based on the diagram, suggest a change that could be made to the piling machine so that the pile can be driven deeper into the ground. Explain your answer. [ 2 ]

---



---



---



---

41. Benny constructed the electrical system shown below. Diagram 1 shows the circuit when switch S is open.

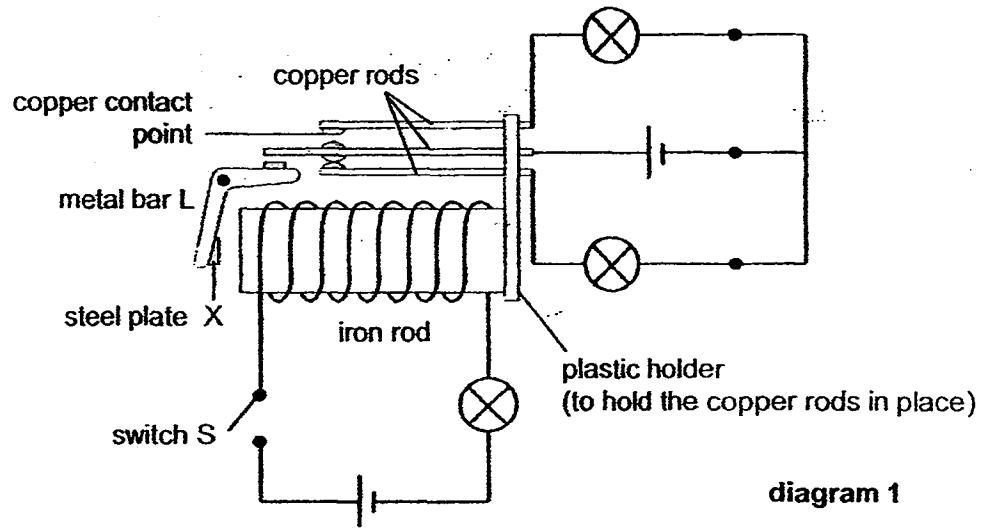

When Benny closed switch S, metal bar L, which was made of aluminium, moved as shown in diagram 2. There were two steel plates attached to the two ends of bar L.

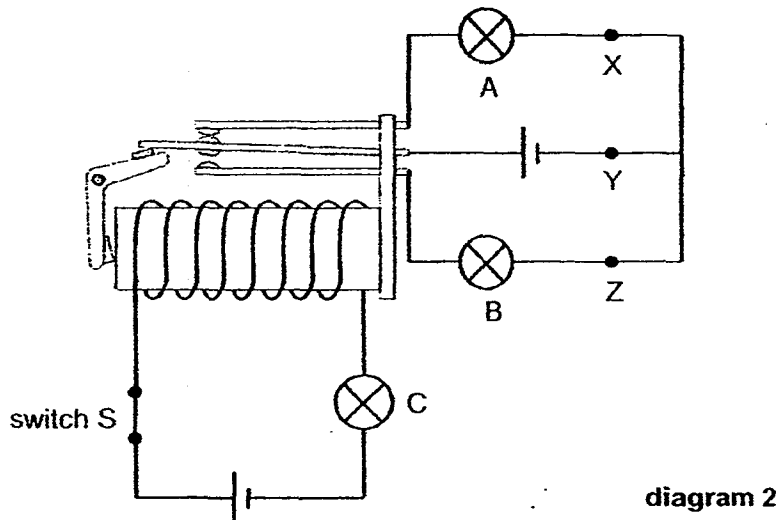

- a) Explain why steel plate X of bar L touched the iron rod after Benny closed switch S. [ 1 ]
- 
- b) Which of the bulbs, A, B or C, would light up when switch S was closed? [ 1 ]
- 
- c) Benny wanted to add an electrical buzzer to his electrical system. He closed switch S and he wanted the buzzer to sound **only** when bulb C is fused. At which position, X, Y or Z, should he place the buzzer? [ 1 ]
-



42. Rita wanted to find out how the boiling point of a liquid affects its rate of evaporation at room temperature.  
She poured equal volume of liquids P, Q and R in three identical dishes as shown below and placed the dishes side by side in the open.

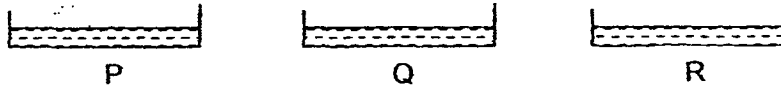

She recorded the volume of the liquid remaining in each of the dish after ten minutes. The table below shows her result.

Liquid	P	Q	R
Boiling Point ( $^{\circ}\text{C}$ )	50	65	80
Volume of liquid at the start of experiment (ml)	10	10	10
Volume of liquid at the end of experiment (ml)	2	7	9

- a) Based on the results, which liquid has the greatest rate of evaporation?  
Give a reason for your answer. [ 1 ]

---

---

- b) Describe the relationship between the boiling point of a liquid and its rate of evaporation. [ 1 ]

---

---

- c) Give a reason how using identical dishes helps to make her experiment a fair test. [ 1 ]

---

---

43. Rani heated some water in a pot. When the water started boiling, she put some meat into the pot and the water stopped boiling for a while.

a) Give a reason why the boiling stopped for a while.

[ 1 ]

---

---

b) Rani heated a balloon with a matchstick and the balloon burst immediately.

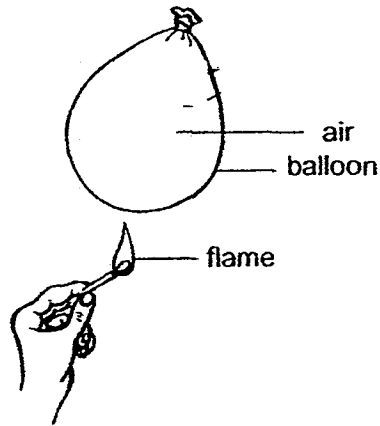

She took another similar balloon, filled it with some water and heated it with another matchstick as shown below.

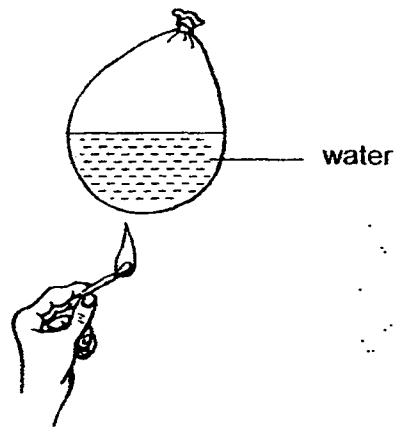

The balloon did not burst this time. Explain why this was so.

[ 2 ]

---

---

---

---

44. Kai carried out an investigation as shown below. He pulled the wooden block by placing its larger surface on the sheet of glass. He then measured the force needed to start moving the block along the glass surface. He repeated the experiment with the smaller surface of the wooden block on the sheet of glass.

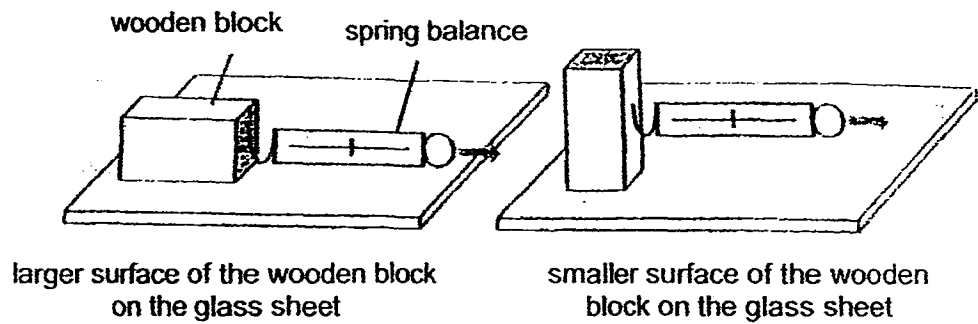

He recorded his results as shown below.

Surface area of the wooden block resting on the glass sheet	Force needed to move the block (units)			
	1 <sup>st</sup> try	2 <sup>nd</sup> try	3 <sup>rd</sup> try	Average
smaller	4.5	4.3	4.4	4.4
larger	4.2	4.5	4.5	4.4

- a) What can Kai conclude from the experiment?

[ 1 ]

---



---

- b) Kai wanted to choose a suitable type of floor tiles for the bathroom floor in his new flat. He repeated the earlier experiment using the same set-up, only replacing the glass sheet with floor tiles A and B as shown below.

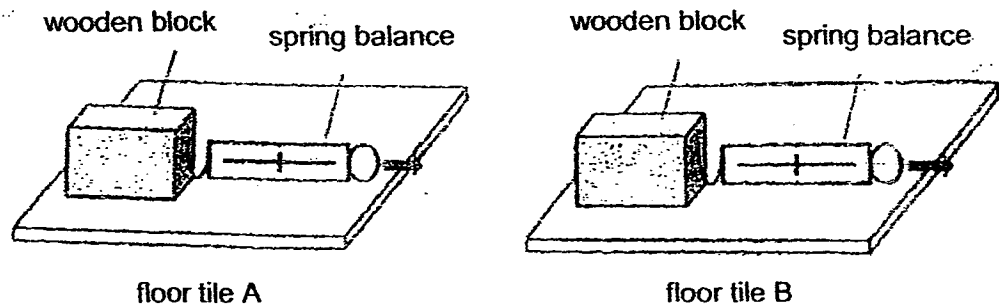

He recorded his results as shown below.

Floor Tile	Force needed to move the block (units)			
	1 <sup>st</sup> try	2 <sup>nd</sup> try	3 <sup>rd</sup> try	Average
A	5.3	5.4	5.5	5.4
B	8.5	8.5	8.2	8.4

Which type of floor tiles, A or B, should Kai use for the bathroom floor so that he will not slip and fall easily? Explain your answer. [ 2 ]

---



---



---



---

**End of Section B**

**EXAM PAPER 2015****LEVEL : PRIMARY 6****SCHOOL : PEI CHUN PUBLIC SCHOOL****SUBJECT : SCIENCE****TERM : PRELIMINARY EXAMINATION****BOOKLET A**

Q 1	Q 2	Q 3	Q 4	Q 5	Q 6	Q 7	Q 8	Q 9	Q 10
2	4	2	1	2	4	1	4	2	1
Q 11	Q 12	Q 13	Q 14	Q 15	Q 16	Q 17	Q 18	Q 19	Q 20
3	2	4	2	4	3	1	1	3	1
Q 21	Q 22	Q 23	Q 24	Q 25	Q 26	Q 27	Q 28	Q 29	Q 30
4	2	1	3	2	2	3	2	2	3

Q31a. 3PM – YELLOW Q31a 3AM – purple

Q31b. The plants in Y received more light than the plants in X, so they photosynthesized faster.

Q32a. To find out how the surface area of the fruit affects the time taken for the fruit to reach the ground.

Q32b. Repeat the experiment two more times / a few times and calculate the average readings for each fruit.

Q33a. The hot water lost heat to the surroundings / surrounding air.

Q33b. As the surface area of water exposed to the air increase, the rate of cooling of hot water increases.

Q33c. K survives better. It has a smaller –exposed surface area of body to the surrounding than J. Si, it loses heat slower to the surroundings.

Q34a. I does not have a cell wall. Q34b. Chloroplasts.

Q35a. As the amount of carbon dioxide in the air increases, the global temperature increases.

Q35b. Less trees takes in less carbon dioxide during photosynthesis. So, more carbon dioxide in the air traps more sun's heat on earth, causing the Earth's temperature to rise, leading to global warming.

Q36a. Not all the seeds will be eaten by it, so the rest will germinate.

Q36b. Animal A disperses the seeds of plant B far away from the parent plant so that the young plant complete less with its parent plants / overcrowding is prevented .

Q36c. It prevents all seeds from being eaten by other animal at one time, so it still have some seeds as food.

Q37. Reason 1 : The population of B was increasing, so more animal B fed on A.

Q 37. Reason 2 : The population of A was increasing before period Z. So, there was not enough X for A to feed on.

Q38a. A would have more carbon dioxide. The plants and snails in A respired to give out carbon dioxide in the airtight terrarium could not escape.

Q38b. The plants gave out water vapor through the stomata of their leaves during evaporation. The warm water vapor lost heat and condensed on the cooler inner surface of A.

Q39a. Air occupied the space in the glass.

Q39b. The person uses up the oxygen in the container.

Q40a. Gravitational potential → Kinetic → Kinetic + heat + sound energy

Q40b. Use a heavier hammer. As the hammer is heavier, more potential energy of the hammer of the hammer is converted to more kinetic of the falling hammer which is transferred to cause a greater force to drive it deeper into the ground.

Q41a. In the closed circuit, the iron rod was magnetized and attracted steel plate X.

Q41b. A and C Q41c. Z

Q42a. P. It has the least volume of liquid at the end of the experiment.

Q42b. As the boiling point of a liquid increases, its rate of evaporation decrease.

Q42c. The exposed surface area of the liquids t the surrounding is the same.

Q43a. The water lost heat to the meat.

Q43b. Water is a better conductor of heat than air. So the water conduct the heat from the flames faster away from the balloon to the surroundings than the air.

Q44a. The surface area of the wooden blocks resting on the glass sheet does not affect the force needed to move the ground.

Q44b. He should use B. The force needed to move the block across B is the greatest. So, the friction between the wooden blocks surface and B's surface is the greatest.

**THE END**